

# Product Catalogue

# P3300i Series Electro/Pneumatic Valve Positioners

## INTRODUCTION

The P3300i series of valve positioners is a milliampere signal version of the P3300 pneumatic valve positioner. It utilises all the features of the P3300 but can operate from a standard 4-20 mA signal.

## CONSTRUCTION

- Case:- Epoxy painted Aluminium as standard.  
Optional Stainless Steel.
- Covers:- Polyester/Aluminium (Epoxy painted).  
Optional Stainless Steel.
- Internals:- Brass/Steel/Aluminium.  
Optional all Stainless Steel.

The case/cover of the positioner are of rugged construction. The positioner is mounted on a heavy duty plate which affords very good resistance to rough handling and vibration.

## ADJUSTMENTS

Zero and span adjustments on the I/P module are easily accessible and are non-interactive.



# kentintrol

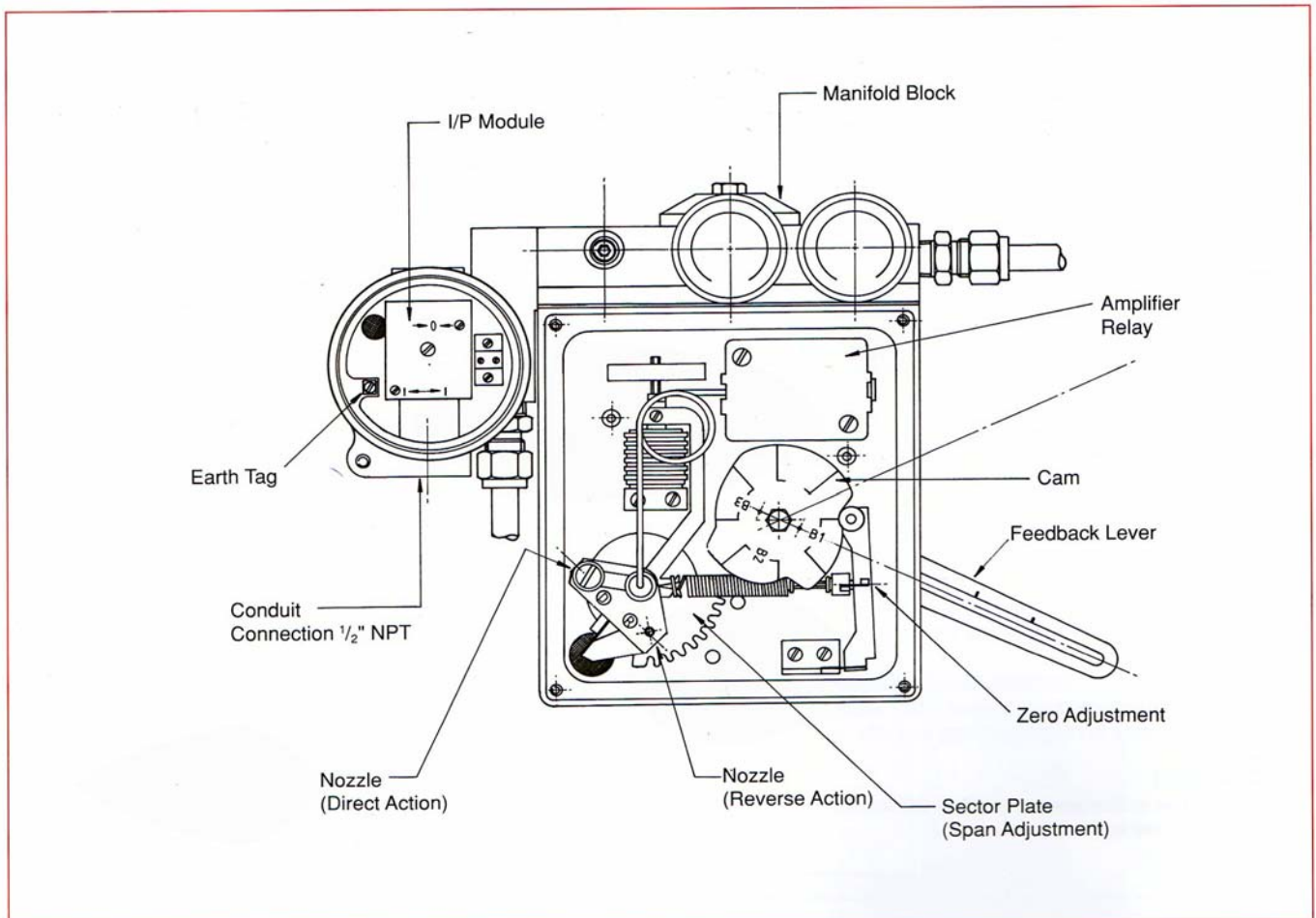

**Positioner – Covers Removed**

## SPECIFICATIONS

### INPUT SIGNAL

4-20 mA dc + split range.

### OUTPUT SIGNAL

Pneumatic pressure as required by actuator up to 95% of supply,

### SUPPLY PRESSURE

M 20 psi (1.4 Bar)  
Max 60 psi (4.1 Bar)

### STROKE LENGTH

Up to 8" travel (max).  
Feedback lever rotation 50°.

### PNEUMATIC CONNECTIONS

1/4" NPT female.

### ELECTRICAL CONNECTION

1/2" NPT female. (Other options on request.)

### ELECTRICAL CERTIFICATION

P3300i/1 - None.  
P3300i/2 - EExib IIc T6.  
P3300i/3 - EExd IIc T4, 15, T6.  
P3300i/4 - Type 'N'.

### INPUT

Current - 4-20 mA.  
Resistance - Approx 200 ohm.  
Capacitance - Negligible.

### OUTPUT (I/P)

Pressure - 0.2- 1.0 Bar (3-15 psi).  
Characteristic - Linear (Direct Acting).  
Consumption - 0.10 kg/h at 4.0 Bar.

**LINEARITY** <1.0%.

**HYSTERESIS** <0.4%.

**REPEATABILITY** <0.01%.

### TEMP RANGE (Operating)

- 20° - +60°C Standard.  
- 40°C to specification.

**MOUNTING POSITION EFFECT** <0.5%

### SHOCK INFLUENCE <1.0% at 5g

Freq. = 10 - 200 HZ  
Amplitude SMAX = 0.5mm.

### WEATHER PROOF RATINGS

I/P Module IP65  
Pneumatic Section IP55.

## PRINCIPLE OF OPERATION (I/P MODULE)

The input current flows through the coil (1), thereby magnetizing the soft iron yoke (2). The flux lines of this system being exposed at the gap (3) apply a force proportional to the input signal to the permanent magnet (4).

The small magnet (4) forms together with the flapper (5), the moving parts controlling the air pressure at the nozzle (6) which is proportional to the magnetic force. The air flowing from the nozzle forms a restoring force balanced by the force applied to the magnet.

The nozzle is supplied with air through a throttle (7) by the output of a power amplifier (8). The described units are matched hence a linear balance of electric input and pneumatic output signal is achieved.

The direction of action is determined by coil polarization.

Zero adjustment is made by twisting the tensioning band (9) at which the flapper (5) is mounted.

Range adjustment is performed at the potentiometer (10) connected with a resistor (ii) in parallel to the coil (1).

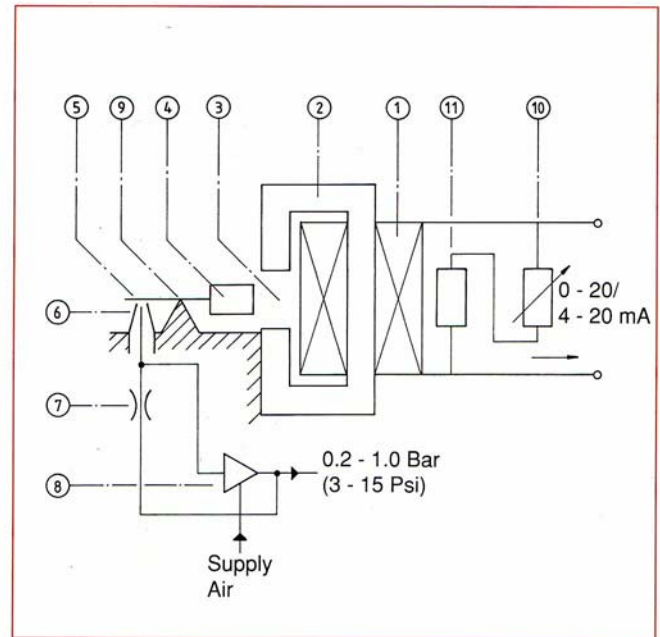

Schematic – I/P Section

## PRINCIPLE OF OPERATION (PNEUMATIC)

A variation of the 4-20 mA input signal causes a variation in the force generated by the bellows unit which changes the state of equilibrium of the mechanism, and consequently produces a change in the modulated signal from the flapper/nozzle/capillary system. The change in signal is amplified in flow and pressure acts on the diaphragm of the actuator producing a and movement the valve stem proportional to the change in value of mA signal. The cam transmits the movement of the stem to feedback spring.

The stem continues to move until the force generated by the bellows unit is balanced by the force generated by the feedback spring. A new equilibrium condition is thus established as a relation between position of the stem and the input signal.

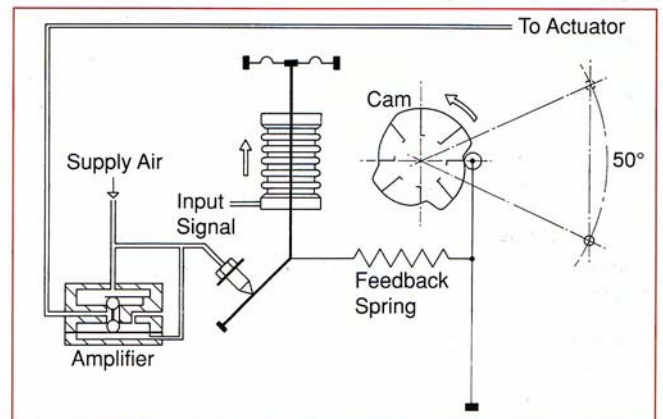

Schematic – Pneumatic Section

## MOUNTING AND CALIBRATION MOUNTING

1. Mount the positioner mounting plate to the actuator yoke using two 5/16" UNC screws.
2. Mount the positioner to the mounting plate using three M6 screws.
3. Check positioner action. (See Fig. 5)  
Switching between Direct and Reverse Action

Direct Action: Increasing input signal gives increasing output

Reverse Action: Increasing input signal gives decreasing output.

For direct action ensure that the switch position on the nozzle is at 'D'. (See Fig. 1).

For reverse action ensure that the switch position on the nozzle is at 'A'. (See Fig. 2).

4. Check Actuator Action. (See Fig. 5)  
Direct actuators (air to close/air fail open).  
Cam should be positioned with side 'A' facing outwards. (See Fig. 3).  
Reverse actuators (air to open/air fail closed).  
Cam should be positioned with side 'B' facing outwards. (See Fig. 4).

5. Check Cam Characteristic  
A/B1 = Linear  
A/B2 = Delayed  
A/B3 = Advanced

6. Before piping positioner output to the actuator apply a pressure value to the actuator to stroke the actuator to 50% of its rated travel.

7. With the positioner feedback arm horizontal fix the drive pin from the stem coupling to the feedback arm, so that the position of the pin corresponds to the valve travel on the feedback arm graduations. Lock the pin in position.

8. The positioner supply and output connections should now be made. The supply pressure to the positioner should be constant and not exceed 4.0 Bar G. If the supply exceeds this limit a filter regulator must be used to avoid damage to the actuator diaphragm.

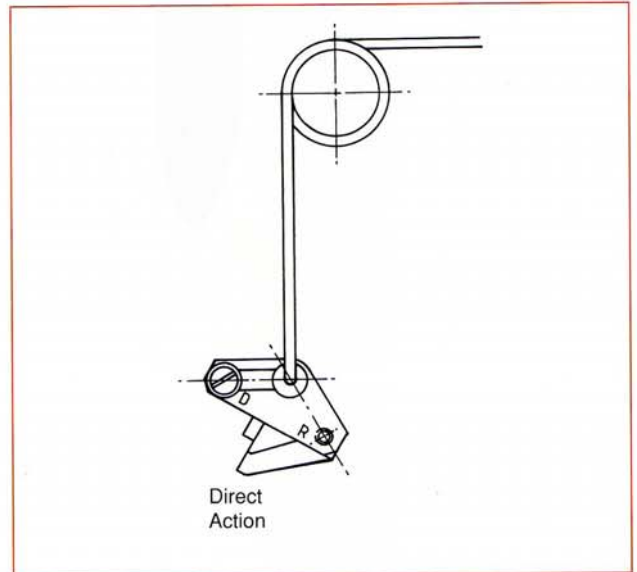

Figure 1.

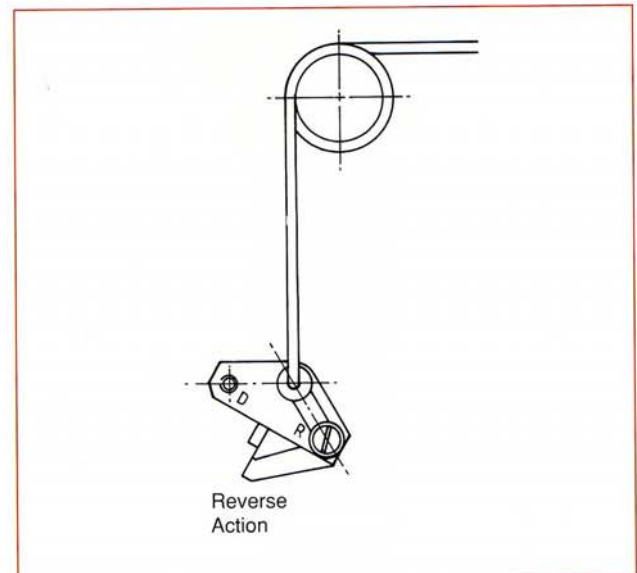

Figure 2.

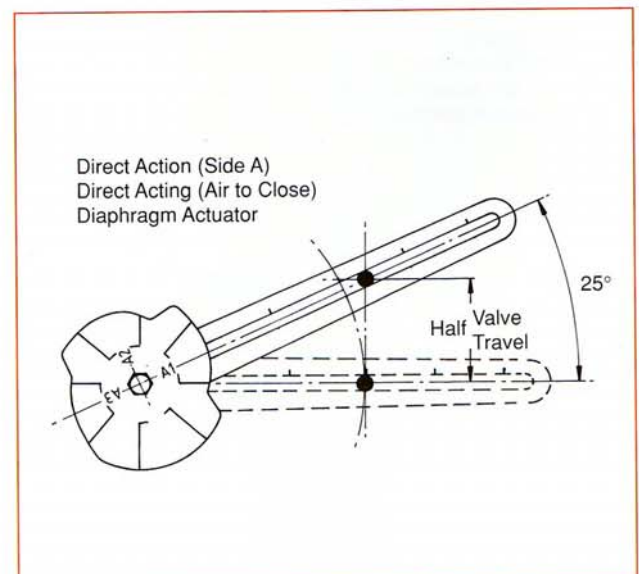

Figure 3.

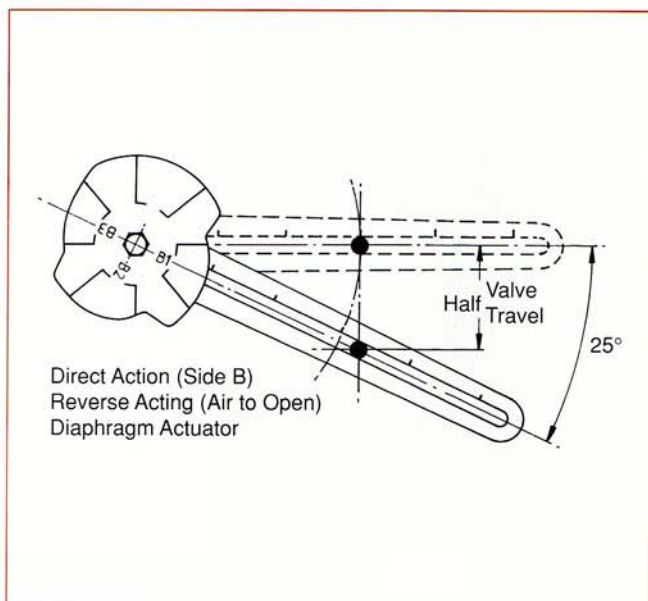

Figure 4.

## CALIBRATION

The calibration of the positioner is carried out in two stages. These are as follows:

### I/P Module

During the calibration of the unit, the valve stem may move. The position of the stem at this stage is of no consequence and should be ignored until final pneumatic calibration.

1. Remove plug from the input gauge port on the positioner manifold block and replace with a 0 - 20 psi or similar pressure gauge.
2. Ensure that there are no air leaks from the positioner and pipework before proceeding.
3. Apply minimum input signal, i.e. 4mA to I/P module.
4. Adjust zero screw on I/P so that a pressure of 3 psi (0.2 Bar) registers on the input gauge.
5. Apply maximum input signal, i.e. 20 mA to I/P module.
6. Adjust span setting on I/P until a pressure of 15 psi (1.0 Bar) registers on the input gauge.

No further calibration of the I/P module should be required as the zero and span settings are non-interactive.

### Pneumatic Section

With the supply and input connections not disturbed, proceed as follows:

1. Apply minimum input signal, i.e. 4mA.
2. Adjust zero screw on positioner until a slight positive pressure reading is observed on the positioner output gauge. (Approx. 1/2 psi).
3. Apply maximum input signal, i.e. 20 mA.
4. Adjust the toothed sector plate with a screwdriver as a lever until the valve reaches the end of its stroke.
5. Re-check zero and span settings and adjust if required.
6. Remove input gauge and re-plug manifold.

### Positioner Spares

Spares kits for both I/P module and pneumatic section are available. Please consult factory for details.

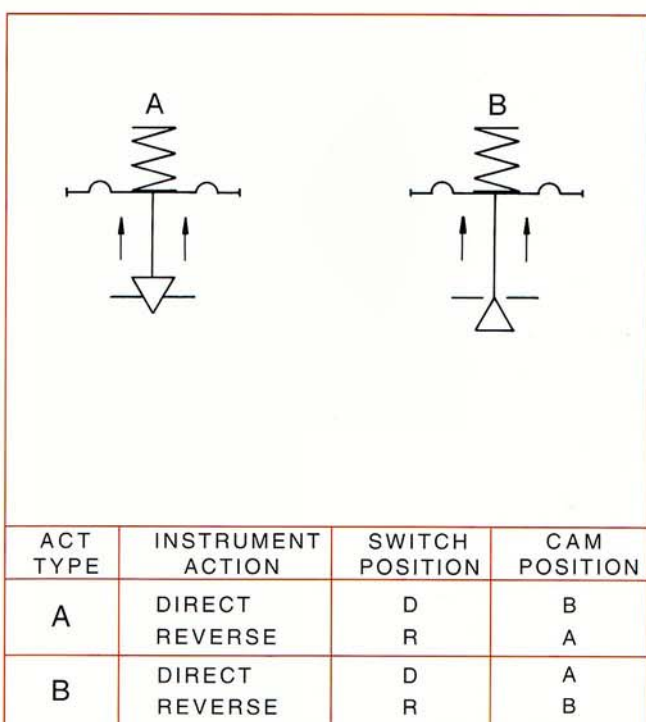

Figure 5.

## **SAFETY MEASURES**

### **IN ORDER TO ENSURE OPERATOR SAFETY AND PLANT SAFETY IT IS IMPORTANT THAT:**

- A Installation and maintenance of this equipment is carried out by suitably trained personnel.
- B Before selecting a location and installing the positioner all the relevant sections of this manual must be read, and the requirements of associated equipment considered.
- C Recommended pressures are not exceeded, all piping and pressure connections are adequate for the duty and are fitted correctly to give reliable pressure tight joints. This is important where compressible fluids (gases, etc.) are concerned, since for these applications a failure under pressure can result in an explosive release of energy.
- D Where equipment such as solenoid valves and limit switches are fitted to the control valve, normal safety precautions must be taken to avoid the possibility of electrical shock.