

PRODUCT SERIES
10/71, 20 & 30

kentintrol

TOP AND BOTTOM GUIDED VALVES



**FORTY
YEARS**

KOSO KENT INTROL SUPPLIES A DIVERSE RANGE OF PRECISION -MANUFACTURED CONTROL, CHOKE, AND ROTARY VALVES FOR OIL AND GAS, PETROCHEMICAL AND POWER INDUSTRIES - WORLDWIDE



TABLE OF CONTENTS

- SERIES 10/71 SINGLE SEATED VALVE	3
- SERIES 20 DOUBLE SEATED VALVE	7
- SERIES 30 THREE WAY VALVE	9
- SELECTION GUIDELINES	11
- DIMENSIONS	13

TOP AND BOTTOM GUIDED VALVES

Top guided control valves have been used for process control since the 1940's. Prior to the 1940's control valves were basic and were unable to produce accurate control of the process fluid. Top guided valves were developed to give accurate and stable control; they were the first valves to offer a characterised plug. The original designs were produced as a single seated valve. But these were later developed into double seated constructions for high capacity applications, and three-way constructions for splitting or mixing flows.

SERIES 10/71

Traditionally top guided valves were used in the vast majority of process applications, however, for today's high performance applications the top guided valves mainly tend to be used in low rated services. The series 10 control valve is a robust, heavy section single seated globe valve with a contoured plug to accurately control the flow through the valve. The series 71 is the angle body version.

SERIES 20

The series 20 valve incorporates two seats which provides a high capacity capability. The guiding of the plug enables the valve to control higher energy flows in a stable manner. The double seated plug is inherently balanced and therefore enables economical actuation of larger valves than on a single seated design.

SERIES 30

The series 30 three way control valves are designed around the series 10 body construction. They are unbalanced valves and primarily used for proportional blending (mixing) of two flows. When flowed in reverse they can be used for flow splitting duties.

SERIES 31

The series 31 three way valve is used for flow splitting duties. The basic body construction is based on the series 20 valve. The valve has one inlet and two outlets for proportional splitting of the process. The plug is inherently balanced.

SERIES 32

The series 32 three way control valves are designed around a cage guided balanced plug construction. They are used for the proportional splitting of flows where actuator sizing is a problem. Flow is from under the valve and is diverted through the straight outlet connections.

QUALITY MANUFACTURING

Maintaining the highest standards of quality throughout design, production and customer service is the cornerstone of Koso Kent Introl's philosophy. Our plant is accredited in accordance with Quality Management System ISO 9001 and Environmental Management System ISO 14001. In addition all products, where applicable, conform to ATEX, PED and all other applicable EU Directives and are CE marked accordingly.

The company's standard manufacturing experience includes NACE MR01.75, Norsok, API 6A specifications and individual customer specifications. Our in-house inspection and testing facilities include hardness testing, NDE, PMI, gas and flow testing. Safety is the key element in everything we do, with all employees undergoing both general and specific Health and Safety training.



SERIES 10/71 SINGLE SEATED GLOBE VALVES

The series 10/71 control valve is a robust, heavy section single seated globe/angle valve with a contoured plug to accurately control the flow through the valve. The trim has a high rangeability and gives Class V shut off capability through metal to metal seating. For bubble tight shut off, Class VI, the plug can be fitted with a PTFE face.

SCOPE OF DESIGN

END CONNECTION SIZES

- 1/2" to 12" (15mm to 300mm) as standard

END CONNECTION STYLES

- Flanged
- Socket Weld
- Threaded
- Butt Weld

VALVE BODY RATINGS

- ANSI 150 to ANSI 600
- Higher on request

DESIGN STANDARD

- ANSI B16.34/PED Certified
- NORSOK/ASME VIII

INHERENT CHARACTERISTIC

- Linear
- Equal Percentage
- Quick Open

SEAT LEAKAGE

- Class III as standard
- Class IV, V special lapped
- Soft Face Seat for Class VI shut off

MATERIAL CONSTRUCTION

- Available in most cast materials

FEATURES

- Top guided with no bottom guide to obstruct the seat bore and potentially trap debris
- All trim components are removable from the top
- Large range of trim CV's per valve size

PERFORMANCE

- High flow capacity
- Tight shut off
- Excellent flow control rangeability
- Cast body proportioned to withstand high pipe stresses without distortion

TRIM DESIGNS

CONTOURED TRIM - AS SHOWN

The contoured plug is designed with a specially profiled valve plug head. The plug head profile determines the flow characteristic through the valve, and offers a smooth profile to the flow leading to a high pressure recovery. The trim is most suited to low pressure drop duties and is used in the majority of control applications.

CONTOURED TRIM SOFT FACED

A variation of the standard contoured plug is the soft faced option. The plug head is manufactured with a clamped on shroud which locks the soft faced ring in position. When the soft face contacts the seating point it deforms the softer ring ensuring a high degree of closure. The soft faced plug is used on duties where bubble tight shut off is required.

Contoured plug



TABLE 1. CV VALUES FOR SERIES 10/71 TRIMS

VALVE SIZE in	mm	TRIM SIZE in	Equal %	CONTOURED TRIM	
				Linear	Quick open
1½	40	1½	32	32	37
		1¼	21	21	23
		1	13.5	13.5	13.5
		¾	8	8	8
2	50	2	50	50	55
		1½	32	32	37
		1¼	21	21	23
		1	13.5	13.5	13.5
3	80	3	110	110	120
		2½	85	85	92
		2	50	50	55
		1½	32	32	37
4	100	4	215	215	225
		3	120	120	130
		2½	85	85	92
		2	50	50	55
6	150	6	440	470	470
		5	325	325	335
		4	215	215	225
		3	120	120	130
8	200	8	620	680	740
		6	440	440	470
		5	325	325	335
		4	215	215	225
10	250	10	930	990	1140
		8	620	680	740
		6	440	440	470
		5	325	325	335
12	300	12	1340	1420	1640
		10	930	990	1140
		8	620	680	740
		6	440	440	470

TABLE 2. CONTOURED CV VALUES FOR ½"-1" (12 – 25mm) VALVE SIZES

VALVE SIZE in	mm	TRIM SIZE in	Equal %	CONTOURED TRIM	
				Linear	Quick open
½	15	⅙	0.4	0.4	-
		⅛	0.63	0.63	-
¾	20	¼	2.0	2.0	-
1	25	⅜	3.2	3.2	-
		½	5	5	5.0
		¾*	8	8	8
		1**	13.5	13.5	13.5

* Only available in valve size ¾" (20mm) and 1" (25mm)

** Only available in Valve size 1" (25mm)
For 1" contoured trim with soft face – CV =11

MICROSPLINE TRIM

The microspline trim design is a seat guided construction, capable of handling high pressure drops, without instability problems. This trim design has an inherent flow characteristic of Mod. =%, and has excellent rangeability. It is an ideal selection for the control of very low flow rates.

For very high pressure drop applications, or flows which would potentially cavitate there are multi-stage options of this design (5 stages maximum), and there are also tungsten carbide and advanced ceramic options for pressure drops greater than 100 bar (1450 psi).

The illustration adjacent represents a single stage design. The flow is controlled by one or more flutes machined into a parallel plug nose. In order to achieve the very low flow control and high rangeability, the plug and seat are manufactured as matched pairs to give a 'gravity slide fit'.

TABLE 3. MICROSPLINE CV VALUES

VALVE SIZE in	mm	TRIM SIZE REF	CHARACTERISTIC MOD. EQUAL %
		No. 00	3.0
		No. 0	1.5
		No.1	0.75
		No. 2	0.45
		No. 3	0.3
½	15	No. 4	0.2
¾	20	No. 5	0.13
1	25	No. 6	0.075
1½	40	No. 7	0.045
		No. 8	0.03
		No. 9	0.02
		No. 10	0.013
		No. 11	0.0075
		No. 13	0.003
		No. 14	0.002
		No. 15	0.0013

On Multi-Stage Trim Designs the No. 00 and No. 0 trims require a 1.1/2" body.
Multi-spline trims only available in sizes No.00 to No.6.

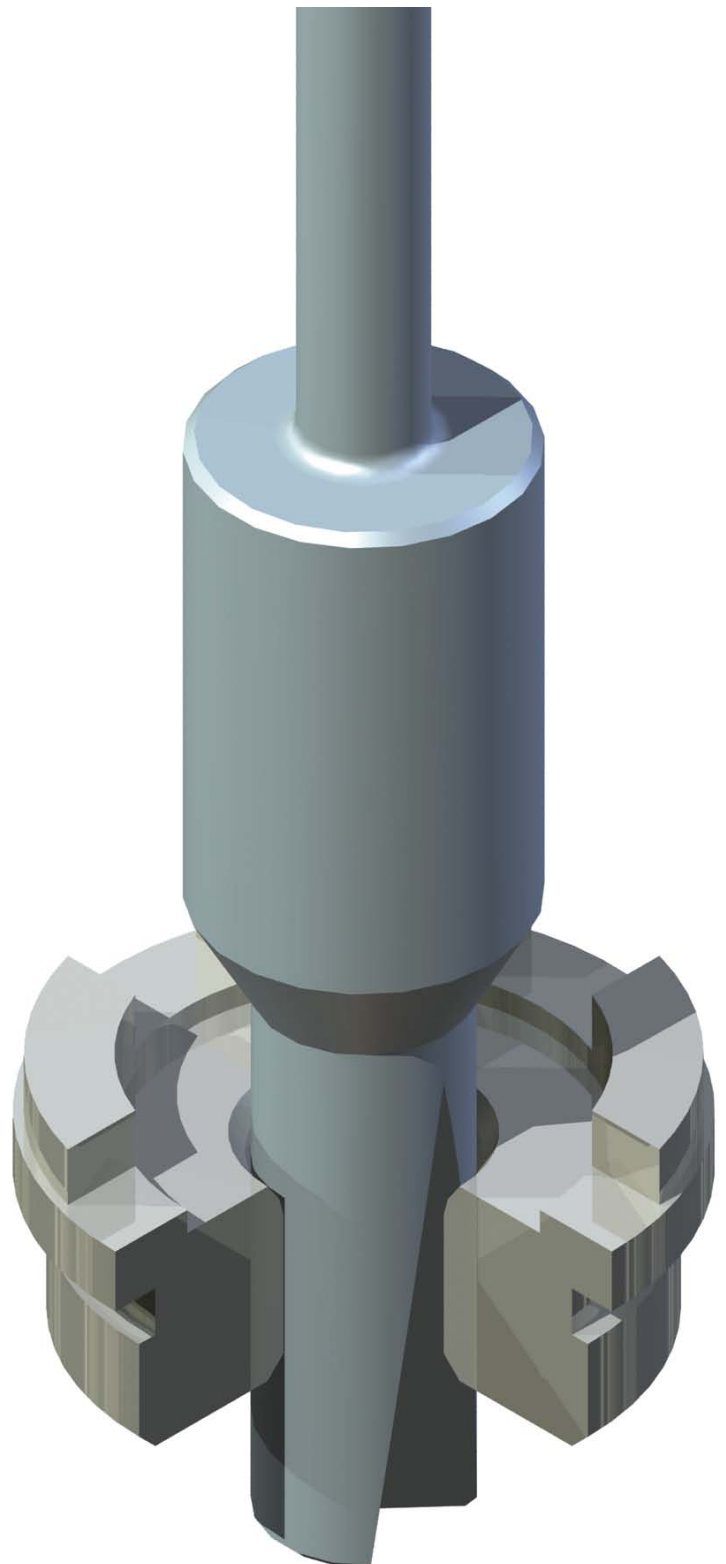

MULTI-STAGE MICROSPLINE TRIM

The trim design presented below right is a Multi-Stage Spline trim. There are 2 Stage, 3 Stage and 5 Stage designs available as standard depending on pressure drop and potential for cavitation. The fluid passes through the flow path generated by incorporating angled flats onto the surface of the plug, together with a cut out on the internal diameter of the seat. The pressure drop is apportioned across the stages of letdown so that the pressure drop progressively reduces as it passes through the stages of the trim.

This gives excellent resistance to cavitation on high pressure drop applications. For very high pressure drop applications the plug and seat insert would be manufactured from tungsten carbide or Advanced Ceramic material. A T-cut section is used to counter any misalignment between the valve stem and actuator.

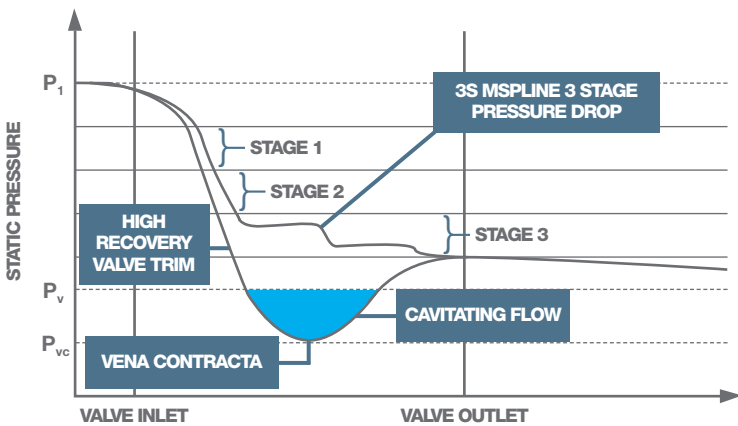

Stage pressure drop

CAVITATION EXPLAINED

Cavitation occurs only in liquid service. In simple terms, cavitation is the two-stage process of vaporisation and condensation of a liquid. Vaporisation is simply the boiling of a liquid, which is also known as FLASHING.

In a control valve this vaporisation takes place because the pressure of the liquid is lowered, instead of the more common occurrence where the temperature is raised. As fluid passes through a valve just downstream of the orifice area, there is an increase in velocity or kinetic energy that is accompanied by a substantial decrease in pressure or potential energy. This occurs in an area called the VENA CONTRACTA.

If the pressure in this area falls below that of the vapour pressure of the flowing fluid, vaporisation (boiling) occurs. Vapour bubbles then continue downstream where the velocity of the fluid begins to slow and the pressure in the fluid recovers. The vapour bubbles then collapse or implode. Cavitation can cause a CHOKED FLOW condition to occur and can cause mechanical damage to valves and piping.

TABLE 4. RANGEABILITY FOR SERIES 10/71 TRIMS

TRIM SIZE REFERENCE	MAXIMUM RANGEABILITY
No. 00 to No. 5	150:1
No. 6 to No. 11	80:1
No. 11 to No. 15	50:1
1/8 to 3/16	40:1
1/4 to 1	55:1
1 1/2 to 3	55:1
4 to 6	70:1
8 to 12	80:1



5 Stage Multi-Spline Trim

SERIES 20 DOUBLE SEATED GLOBE VALVES

The series 20 valve incorporates two seats which results in a higher capacity capability than the Series 10. The guiding of the plug enables the valve to control higher energy flows in a stable manner. Double seated valves are inherently balanced and therefore enables economical actuation of larger valves than with a single seated design. The design can be used for medium and low pressure applications where tight shut off is not important. For high capacity applications where high pressure drops occur then the series 20 valve can be fitted with the HF style trim.

SCOPE OF DESIGN

END CONNECTION SIZES

- 1.5" to 24"
(40mm to 600mm)

END CONNECTION STYLES

- Flanged

VALVE BODY RATINGS

- ANSI 150 to ANSI 600 as standard, higher ratings on request

DESIGN STANDARD

- ANSI B16.34/PED Certified
- NORSOK/ASME VIII

INHERENT CHARACTERISTIC

- Linear
- Quick Open
- Equal Percentage

SEATING

- Metal to Metal for up to Class III shut off

MATERIALS CONSTRUCTION

- Available in most cast materials

FEATURES

- Top and bottom guided
- Anti-cavitation/low noise trim option for high pressure drop applications
- All components serviceable from the top
- Multi trim sizes available per valve size

PERFORMANCE

- High flow capacity
- Minimum differential plug areas to reduce actuator force requirements
- Excellent flow control rangeability
- Cast body proportioned to withstand high pipe stresses without distortion

TRIM DESIGNS

CONTOURED TRIM

The contoured plug is designed with a specially profiled valve plug head. The plug head profile determines the flow characteristic through the valve, and offers a smooth profile to the flow leading to a high pressure recovery. The trim is most suited to low pressure drop application and is used in the majority of control applications.

HIGH FRICTION HIGH CAPACITY TRIM

The high friction trim has been developed for higher pressure drop applications and where high capacity flows are required. The trim is manufactured with high friction style extended seat rings to ensure low pressure recoveries. This means that the trim is ideal for preventing the onset of cavitation and reducing noise levels generated as a result of both liquid and gas/vapour flows.



TABLE 5. SERIES 20 CV VALUES

VALVE SIZE in	mm	TRIM SIZE in	CONTOURED TRIM			HIGH FRICTION HF	
			Equal %	Linear	Quick open	Equal %	Linear
1½	40	1½	38	38	38	38	38
		1¼	25	25	25	25	25
		1	18	18	18	-	-
2	50	2	67	67	67	67	67
		1½	38	38	38	38	38
		1¼	25	25	25	25	25
3	80	3	144	144	144	144	144
		2½	105	105	105	105	105
		2	67	67	67	67	67
4	100	4	258	258	258	258	258
		3	144	144	144	144	144
		2½	105	105	105	105	105
6	150	6	535	575	575	535	575
		5	385	405	405	385	405
		4	258	258	258	258	258
8	200	8	865	1012	1012	865	1012
		6	535	575	575	535	575
		5	385	405	405	385	405
10	250	10	1375	1456	1456	1375	1456
		8	865	1012	1012	865	1012
		6	535	575	575	535	575
12	300	12	1725	1850	1850	1725	1850
		10	1375	1456	1456	1375	1456
		8	865	1012	1012	865	1012
14	350	14	2525	2689	2689	2150	2330
		12	1725	1850	1850	1725	1850
		10	1375	1456	1456	1375	1456
16	400	16	3290	3504	3504	2800	2987
		14	2525	2689	2689	2150	2330
18	450	18	4200	4473	4473	3560	3809
		16	3290	3504	3504	2800	2987
20	500	20	5170	5506	5506	4380	4687
		18	4200	4473	4473	3580	3809
24	600	24	7420	7902	7902	6310	6770
		22	6250	6656	6656	5320	5719

TABLE 6. RANGEABILITY VALUES FOR SERIES 20 CONTOURED AND HF TRIMS

TRIM SIZE	MAXIMUM RANGEABILITY
1½ to 3	30:1
4 to 6	40:1
8 to 12	45:1
14 to 24	50:1

SERIES 30, 31 & 32 THREE WAY VALVES

SCOPE OF DESIGN

END CONNECTION SIZES

- 11/2" to 12" (40mm to 300mm) nominal bore

END CONNECTION STYLES

- Flanged

VALVE BODY RATINGS

- ANSI 150 to ANSI 600 as standard, higher ratings on request

DESIGN STANDARD

- ANSI B16.34/PED Certified
- NORSOK/ASME VIII

INHERENT CHARACTERISTIC

- Linear

SEATING

- Metal to Metal for up to Class V shut off

MATERIALS CONSTRUCTION

- Available in most castable materials

FEATURES

- Top guided plug with additional skirt guiding through the seat rings
- effective on both seats
- Most components serviceable from the top
- Multi trim sizes available

PERFORMANCE

- High flow capacity
- Minimum differential plug areas to reduce actuator force requirements (Series 31 and 32 valves)
- Excellent flow control rangeability

SERIES 30

The series 30 three way control valves, image A, are designed around the series 10 body construction. They are unbalanced valves and primarily used for proportional blending (mixing) of two flows. When flowed in reverse they can be used for flow splitting duties.

SERIES 31

The series 31 three way valve, image B, is used for flow splitting duties. The basic body construction is based on the series 20 valve. The valve has one inlet and two outlets for proportional splitting of the process. The plug is inherently balanced.

SERIES 32

The series 32 three way control valves are designed around a cage guided balanced plug construction. They are used for the proportional splitting of flows where there would otherwise be high unbalanced forces acting on the plug. Flow is from under the valve.

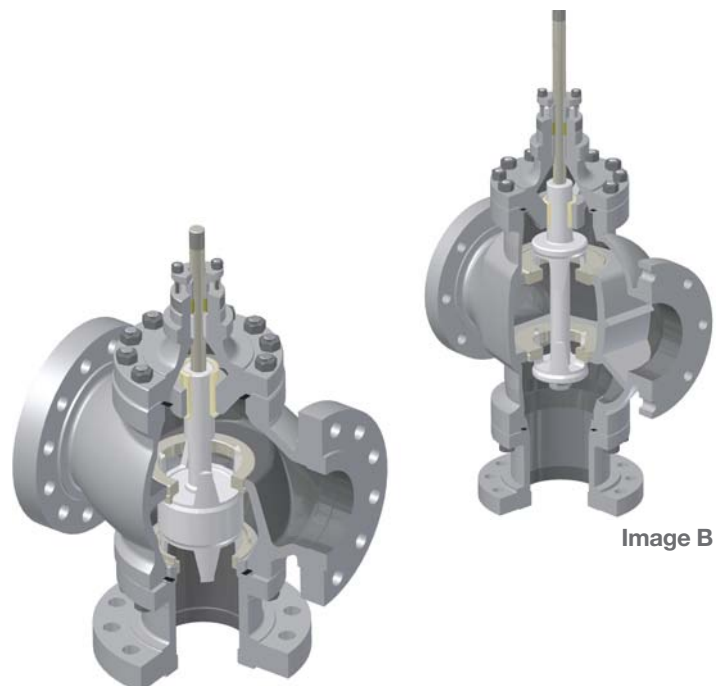

Image A

Image B

TRIM DESIGNS

SERIES 30A - MIXING (BLENDING) SERVICE

When used on mixing service the series 30 valve has two separate inlets and one common outlet. The flows are proportionally blended into one stream by control of the valve plug position. The standard plug is a linear 'V' port design and provides a high flow capacity, coupled with high rangeability.

SERIES 30B - SPLITTING (DIVERTING) SERVICE

When flowed in reverse the series 30 valve can be used for splitting the flows. On this duty the valve has one common inlet and flow is proportionally split between the two outlets. The total outlet capacity is constant irrespective of the plug position.

Mixing
(Blending)
Service

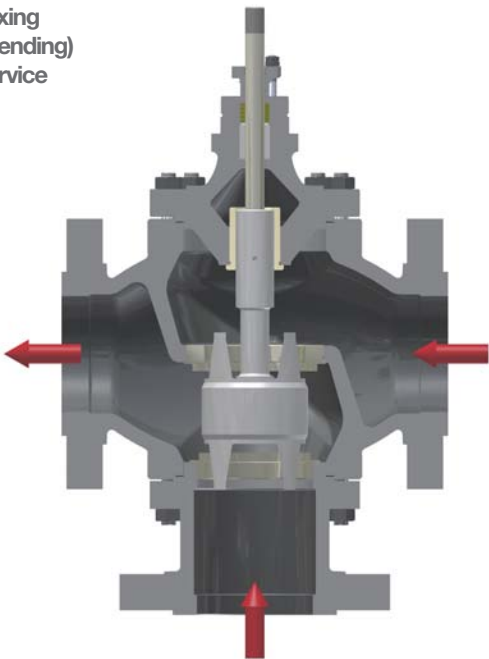

Splitting
(Diverting)
Service

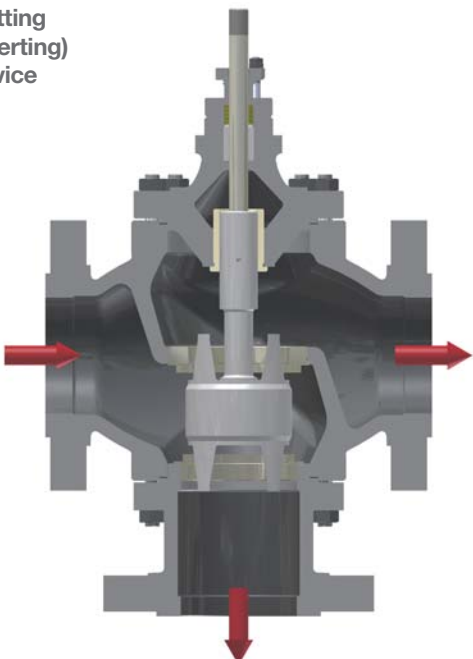

SERIES 31 - SPLITTING (DIVERTING) SERVICE

The series 31 valve is based on the series 20 body pattern with an additional body rib inserted to separate the flow streams. The under/over flow regime means that the plug is inherently balanced meaning that size for size a smaller actuator can be utilised when compared with using a series 30 valve.

SERIES 32 - SPLITTING (DIVERTING) SERVICE

The series 32 valve design is based on a series 10 body casting. A bottom flange is fitted on the bottom of the body as an inlet connection. The trim is cage guided with a balanced plug. Depending on the plug position flow is proportionally directed to the left or right hand outlet branch.

The trim design is either ported or HF. The balanced trim construction allows the potential for high flow rates while the actuator size is kept to a minimum.

TABLE 7. SERIES 30/31 DESIGN CV VALUES

VALVE SIZE in	mm	TRIM SIZE in	CHARACTERISTIC Linear
1½	40	1½	28
		1¼	17
2	50	2	42
		1½	28
3	80	3	105
		2½	70
4	100	4	195
		3	105
6	150	6	405
		5	275
8	200	8	605
		6	405
10	250	10	881
		8	605
12	300	12	1264
		10	881

Consult factory for CV Values of Series 32 Valves

TABLE 8. SERIES 30/31 RANGEABILITY

TRIM SIZE in	MAXIMUM RANGEABILITY
1½ to 3	48:1
4 to 12	65:1

SELECTION GUIDELINES

VELOCITY LIMITATIONS

In selecting a valve for either a liquid or gas/vapour application one of the major considerations is the effect of fluid velocity. High velocity could lead to operational problems including erosion, excessive vibration and instability.

The following tables indicate the maximum recommended velocity values for liquid and gas/vapour services.

TABLE 9. RECOMMENDED MAXIMUM VELOCITIES FOR LIQUID FLOW

TRIM DESIGN	VALVE SIZE		CARBON STEEL		ALLOY STEEL		BRONZE, CU, NI, ALLOY	
	in	mm	ft/s	m/s	ft/s	m/s	ft/s	m/s
Microspline	½ to 2	15 to 50	43	13.1	52	15.8	26	7.6
Contoured/V ported	½ to 2	15 to 50	41	12.5	46	14	25	7.6
	3 to 6	80 to 150	34	10.4	34	10.4	20	6.2
	8 to 14	200 to 350	29	8.9	29	8.9	17	5.2
	16 to 18	400 to 450	22	6.7	22	6.7	13	14
	20	500	18	5.5	18	5.5	11	3.4
	24	600	12	3.7	12	3.7	7	2.1
HF	1 to 12	25 to 300	43	13.1	52	15.8	26	7.6
	14 to 20	350 to 500	35	10.7	43	13.1	21	6.4
	24	600	25	7.6	35	10.7	15	4.6

TABLE 10. RECOMMENDED MAXIMUM VELOCITIES FOR GAS/VAPOURS FLOWS

TRIM DESIGN	VALVE SIZE		MAXIMUM INLET		MAXIMUM OUTLET		MAXIMUM OUTLET MACH. >95dBA >90dBA >85dBA NUMBER FOR REQUIRED NOISE LEVEL		
	in	mm	ft/s	m/s	ft/s	m/s			
Microspline	½ to 2	15 to 50	475	144	830	253	0.65	0.5	0.3
Contoured/V ported	½ to 2	15 to 50	340	104	830	253	0.65	0.5	0.3
	3 to 6	80 to 150	295	90	830	253	0.65	0.5	0.3
	8 to 14	200 to 350	265	81	830	253	0.65	0.5	0.3
	16 to 18	400 to 450	190	58	830	253	0.65	0.5	0.3
	20	500	150	46	830	253	0.65	0.5	0.3
	24	600	115	35	830	253	0.65	0.5	0.3
HF	1 to 24	25 to 600	475	144	830	253	0.65	0.5	0.3

MATERIALS OF CONSTRUCTION

Valve trim materials are selected based on the process fluid, pressure drop, process contamination, etc. Listed below are the standard material used in selecting the appropriate trim design and trim materials. On liquid flows it is always necessary to consider the potential for cavitation or flashing.

TABLE 11. TRIM MATERIAL COMBINATIONS

TYPICAL DUTY	PLUG	SEAT	STEM	GUIDE BUSH	PACKING PARTS
Standard Duty	316 st. st	316 st. st	316 st. st	440C st.st	316 st. st.
NACE	316 st. st	316 st. st	316 st. st	Stellite	316 st. st
Acids	Hastelloy B/C	Hastelloy B/C	Hastelloy B/C	Stellite	Hastelloy B/C
Acids	Alloy 20	Alloy 20	Alloy 20	Stellite	Alloy 20
Seawater/Corrosive	Monel 400	Monel K500	Monel K500	Monel K500	Monel 400
NACE/Seawater	Duplex	Duplex	Duplex	Stellite	Duplex

TABLE 12. OVERLAY OPTIONS

	PLUG	SEAT			
Moderate pressure drop (15 bar/200psi)	Gr.6 Stellite Face	Gr.6 Stellite Face	-	-	-
Moderate pressure drop (30 bar/400psi)	Full Gr.6 Stellite	Gr.6 Stellite Face	-	-	-

TABLE 13. BONNET AND PACKING SELECTION

COMPONENT	BELOW -100°C (-150°F)	-100°C TO -20°C (-150°F to -4°F)	-20°C TO 250°C (-4°F to 482°F)	250°C TO 400°C (482°F to 752°F)	ABOVE 400°C (752°F)
Bonnet	Cryogenic	Normalising	Standard	Normalising	Normalising
Packings	PTFE Chevron	PTFE Chevron	PTFE Chevron	Graphite	Graphite (*)

*Not on oxidizing services.

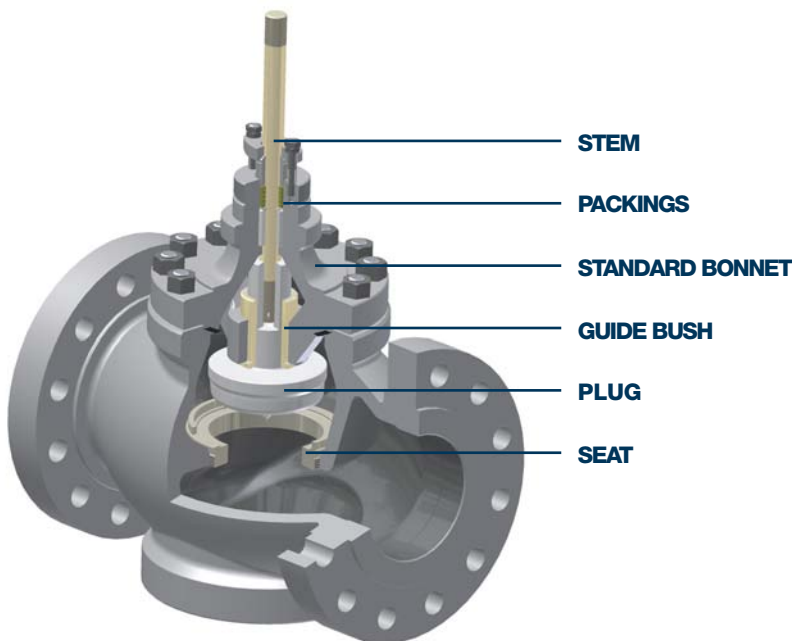

Bellows Bonnet for applications where gland leaks cannot be tolerated

DIMENSIONAL INFORMATION

SERIES 10

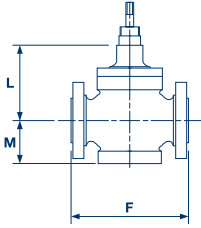

SERIES 20

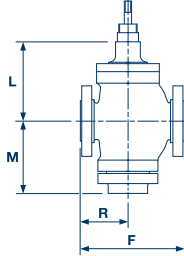

SERIES 30

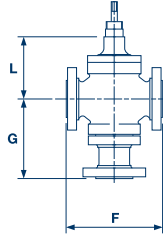

SERIES 31

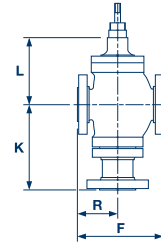

TABLE 14. SERIES 10 DIMENSIONS FOR LOW RATED VALVES

		1/2"	3/4"	1"	1 1/2"	2"	3"	4"	6"	8"	10"	12"	14"	16"	18"	20"	24"
		15mm	20mm	25mm	40mm	50mm	80mm	100mm	150mm	200mm	250mm	300mm	350mm	400mm	450mm	500mm	600mm
ANSI 150 and PN10 & 16	F	7 1/4 184	7 1/4 184	7 1/4 184	8 3/4 222	10 254	11 3/4 298	13 7/8 352	17 3/4 451	21 3/8 543	26 1/2 673	29 737	35 889	40 1016	45 5/8 1153	54 1372	58 1/4 1480
	G	6 1/4 159	6 1/4 159	6 1/4 159	6 3/8 162	7 1/16 180	9 3/16 233	10 7/16 265	12 13/16 325	15 11/16 398	16 7/16 418	17 1/16 433	-	-	-	-	-
	K	-	-	-	7 3/4 197	8 1/2 216	10 7/8 276	13 1/8 333	15 5/8 397	19 483	21 1/4 540	22 1/8 562	-	-	-	-	-
ANSI 300 and PN25 & 40	F	7 1/2 191	7 5/8 194	7 3/4 197	9 1/4 235	10 1/2 267	12 1/2 318	14 1/2 368	18 5/8 473	22 3/8 568	27 1/8 708	30 1/2 775	36 1/2 927	41 5/8 1057	47 1194	55 5/8 1413	60 1524
	G	6 1/4 159	6 1/4 159	6 1/4 159	6 3/8 162	7 1/16 180	9 3/16 233	10 7/16 265	12 13/16 325	15 11/16 398	16 7/16 418	17 1/16 433	-	-	-	-	-
	K	-	-	-	7 3/4 197	8 1/2 216	10 7/8 276	13 1/8 333	16 5/16 414	19 13/16 503	22 1/8 562	23 584	-	-	-	-	-
ANSI 600 and PN100	F	8 203	8 1/8 206	8 1/4 210	9 7/8 251	11 1/4 286	13 1/4 337	15 1/2 394	20 508	24 610	29 5/8 752	32 1/4 819	38 1/4 972	43 5/8 1108	49 1/4 1251	58 1473	63 1600
	G	6 1/4 159	6 1/4 159	6 1/4 159	6 3/8 162	7 1/16 180	9 3/16 233	10 7/16 265	16 5/16 414	16 7/16 418	17 5/16 440	17 15/16 455	-	-	-	-	-
	K	-	-	-	6 3/8 162	7 1/16 180	9 3/16 233	10 7/16 265	13 7/8 352	16 7/16 418	17 5/16 440	17 15/16 455	-	-	-	-	-
ANSI 600 RTJ Series 10/30	F	8 203	8 1/8 206	8 1/4 210	9 7/8 251	11 1/4 286	13 3/8 340	15 5/8 397	20 1/8 511	24 1/8 613	30 1/8 765	32 3/8 823	-	-	-	-	-
ANSI 600 RTJ Series 20/31	F	-	-	-	9 7/8 251	11 1/4 286	13 3/8 340	15 5/8 397	20 1/8 511	24 1/8 613	30 1/8 765	32 3/8 823	-	-	-	-	-
Standard Bonnet Series 10/30	L	5 1/2 140	5 1/2 140	5 1/2 140	6 1/4 159	6 5/8 168	8 203	8 1/8 206	10 7/8 276	11 3/4 298	15 1/2 394	15 1/2 394	-	-	-	-	-
Normalising Bonnet Series 10/30	L	8 3/4 222	8 3/4 222	8 3/4 222	11 1/2 292	11 3/4 298	12 7/8 327	14 357	15 3/8 391	17 1/8 435	25 635	26 11/16 678	-	-	-	-	-
Bellows Bonnet Series 10/30	L	12 3/4 324	12 3/4 324	12 3/4 324	13 15/16 354	14 1/4 362	18 5/16 465	18 3/8 467	26 7/8 683	27 5/16 694	36 7/16 926	36 15/16 938	-	-	-	-	-
Standard Bonnet Series 20/31	L	12 3/4 324	12 3/4 324	12 3/4 324	7 7/16 189	7 7/8 200	9 1/2 241	10 5/8 270	13 1/2 343	14 7/8 378	20 1/4 514	20 3/8 518	22 1/2 572	31 787	30 1/4 768	35 1/2 902	48 1219
Normalising Bonnet Series 20/31	L	-	-	-	12 2/4 322	13 330	14 3/8 365	16 1/2 419	18 457	20 1/2 521	29 3/4 756	31 1/2 802	34 3/4 883	39 1/4 997	43 1/8 1094	49 1/2 1257	56 1/2 1435
Bellows Bonnet Series 20/31	L	-	-	-	15 1/8 384	15 1/2 394	19 7/8 503	20 7/8 529	29 1/2 749	30 1/2 773	41 1/4 1048	41 7/8 1062	45 1/8 1146	49 5/8 1260	55 1397	59 1/2 1511	65 1/8 1654
Valve Stroke	A	1 1/8 28	1 1/8 28	1 1/8 28	1 1/8 28	1 1/8 28	1 1/2 38	1 1/2 38	2 1/4 57	2 1/4 57	3 1/2 89	3 1/2 89	3 1/2 89	3 1/2 89	4 102	5 127	5 127
Series 10 to ANSI 600	M	2 5/8 67	2 5/8 67	2 5/8 67	3 1/4 83	3 3/8 86	4 3/8 111	5 3/4 146	6 3/4 171	8 203	9 3/8 238	9 7/8 251	-	-	-	-	-
Series 20 to ANSI 600	M	-	-	-	5 1/2 140	5 7/8 149	7 5/8 194	10 254	11 3/8 289	13 1/2 341	17 3/8 441	18 1/2 470	18 5/8 473	27 1/2 698	29 1/2 749	34 3/4 883	46 1/4 1175
Bonnet Mount Dia (All)	A	2 1/8 54	2 1/8 54	2 1/8 54	2 1/8 54	2 1/8 54	2 13/16 71	2 13/16 71	3 9/16 90	3 9/16 90	3 9/16 90	3 9/16 90	5 3/4 146	5 3/4 146	5 3/4 146	5 3/4 146	5 3/4 146
Stem Up Position	A	4 5/8 117	4 5/8 117	4 5/8 117	4 5/8 117	4 5/8 117	5 5/8 143	5 5/8 143	7 3/4 197	7 3/4 197	9 229	9 229	-	-	-	-	-
Stem Conn. Dia	A	3/8 9.5	3/8 9.5	3/8 9.5	1/2 12.7	1/2 12.7	5/8 16	3/4 19	1 25.4	1 25.4	1 1/4 31.8	1 1/4 31.8	-	-	-	-	-

NOTE: Face to face dimensions comply with ANSI ISA S75.03. All dimensions will be confirmed in the event of an order.

TABLE 15. SERIES 10 DIMENSIONS FOR HIGH RATED VALVES

DESCRIPTION	DIM.	½" 15mm	¾" 20mm	1" 25mm	1½" 40mm	2" 50mm
ANSI 900/1500	F	8½ 216	9½ 232	9½ 238	11 279	12¼ 311
ANSI 2500	F	10½ 267	10¾ 273	11 279	15 381	17 432
Standard Bonnet ANSI 900/1500	L	5½ 140	5½ 140	5½ 140	7½ 191	7½ 191
Normalising Bonnet ANSI 900/1500	L	8¾ 222	8¾ 222	8¾ 222	9⅝ 244	9⅝ 244
Standard Bonnet ANSI 2500	L	7¼ 184	7¼ 184	7¼ 184	7½ 191	7½ 191
Normalising Bonnet ANSI 2500	L	9⅝ 232	9⅝ 232	9⅝ 232	14⅛ 357	14⅛ 357
CL to Base ANSI 900/1500	M	2¾ 70	2¾ 70	2¾ 70	3⅝ 86	3⅝ 86
CL to Base ANSI 2500	M	2½ 64	2½ 64	2½ 64	3 76	3⅝ 100
Bonnet Mount Dia ANSI 900/1500		2½ 54	2⅝ 54	2⅝ 54	2⅝ 54	2⅝ 54
Bonnet Mount Dia ANSI 2500		2½ 54	2⅝ 54	2⅝ 54	2⅝ 71	2⅝ 71
Stem Conn. Dia ANSI 900/1500		¾ 9.5	¾ 9.5	¾ 9.5	½ 12.7	½ 12.7
Stem Conn. Dia ANSI 2500		½ 12.7	½ 12.7	½ 12.7	½ 12.7	½ 12.7
Net Weight ANSI 900/1500	kg	27	27	27	37	51
Net Weight ANSI 2500	kg	32	32	32	62	86

TABLE 16. SERIES 10 VALVE WEIGHTS KG (STANDARD BONNET)

SERIES	RATING	½"-1"	1½"	2"	3"	4"	6"	8"	10"	12"	14"	16"	18"	20"	24"
		15-25mm	40mm	50mm	80mm	100mm	150mm	200mm	250mm	300mm	350mm	400mm	450mm	500mm	600mm
10	ANSI 150	13	20	30	44	90	160	277	469	676	-	-	-	-	-
	ANSI 300	15	22	33	49	97	171	292	505	725	-	-	-	-	-
	ANSI 600	20	29	41	63	119	205	343	601	855	-	-	-	-	-
20	ANSI 150	15	34	46	81	129	187	332	577	873	1225	1600	1744	2310	-
	ANSI 300	18	38	49	87	138	200	358	632	930	1280	1675	2075	2450	-
	ANSI 600	22	49	55	103	158	270	528	902	1254	1650	2060	2450	-	-
30	ANSI 150	18	34	56	82	184	314	581	1010	1466	-	-	-	-	-
	ANSI 300	22	39	62	93	199	348	613	1089	1574	-	-	-	-	-
	ANSI 600	35	54	81	125	247	421	725	1301	1858	-	-	-	-	-

TABLE 17. LEAKAGE CLASS

VALVE DESIGN	SEATING STYLE	ANSI LEAKAGE CLASS	MAXIMUM ALLOWABLE LEAKAGE
Series 20	Metal to Metal	Class III	0.1% Rated Capacity
Series 10, 30, 31, 32	Metal to Metal (Series 32 valve fitted with resilient seal)	Class IV	0.01% of Rated Capacity
Series 10, 30, 31, 32	Metal to Metal with lapped seats (Series 32 valve fitted with resilient seal)	Class V	0.0005ml/min of water per inch of port diameter per PSI differential
Series 10	Metal with Resilient Seat	Class VI	Bubbles



KOSO KENT INTROL LIMITED
ARMYTAGE ROAD
BRIGHOUSE
WEST YORKSHIRE
HD6 1QF

TELEPHONE
+44 (0)1484 710311

FACSIMILE
+44 (0)1484 407407

EMAIL
info@kentintrol.com

WEBSITE
WWW.KENTINTROL.COM



KOSO

Koso Kent Introl Limited is part of the KOSO Group of companies.

The Company's policy is one of continual development and the right is reserved to modify the specifications contained herein without notice.

Copyright © January 2009
All rights reserved Koso Kent Introl Limited